

Tarmac Building Products Limited

i10 Building
Railway Drive
Wolverhampton WV1 1LH



Tel: 0345 013 3592

e-mail: aircretetechnical@tarmacbp.co.uk

website: www.tarmacbuildingproducts.co.uk

Agrément Certificate

02/3896

Product Sheet 1

TOPLITE AIRCRETE BLOCKS

TOPLITE STANDARD AND FOUNDATION

This Agrément Certificate Product Sheet⁽¹⁾ relates to Toplite Standard and Foundation, general purpose, autoclaved aerated concrete (Aircrete) building blocks, for use above and below the damp-proof course in the construction of loadbearing and non-loadbearing solid internal and external walls, and the inner and outer leaves of cavity walls.

(1) Hereinafter referred to as 'Certificate'.

CERTIFICATION INCLUDES:

- factors relating to compliance with Building Regulations where applicable
- factors relating to additional non-regulatory information where applicable
- independently verified technical specification
- assessment criteria and technical investigations
- design considerations
- installation guidance
- regular surveillance of production
- formal three-yearly review.

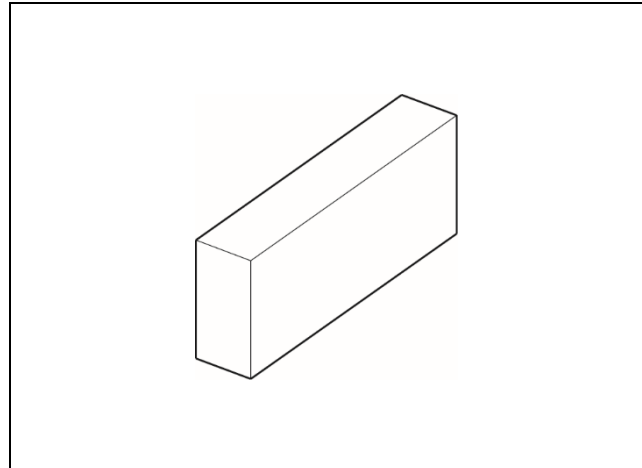

KEY FACTORS ASSESSED

Strength and stability — the blocks have a mean compressive strength of 3.6 N-mm⁻² and are suitable for use in walls designed and constructed in accordance with BS EN 1996-1-1 : 2005, BS EN 1996-1-2 : 2005, BS EN 1996-2 : 2006 and BS EN 1996-3 : 2006 and their UK National Annexes, and PD 6697 : 2010 (see section 6).

Thermal performance — the thermal conductivity (λ value) of the blocks may be taken as 0.16 W·m⁻¹·K⁻¹⁽¹⁾ in 'protected blockwork' applications (see section 7).

(1) 0.15 W·m⁻¹·K⁻¹ ($\lambda_{10, dry}$), declared dry value.

Sound insulation — the blocks may be used in separating walls and in flanking elements to separating walls and floors (see section 8).

Properties in relation to fire — the blocks are 'non-combustible' as defined in the national Building Regulations (see section 9).

Use below the damp-proof course — the blocks are suitable for use in situations up to and including MX3.2 as defined in BS EN 1996-2 : 2006 or A3 as defined in PD 6697 : 2010, or in Classes DS1, DS2 and DS3 of soil and groundwater as defined in BRE Special Digest 1 : 2005 (see section 10).

Durability — walls constructed using the blocks will have a durability equivalent to those of traditional masonry (see section 15).



The BBA has awarded this Certificate to the company named above for the products described herein. These products have been assessed by the BBA as being fit for their intended use provided they are installed, used and maintained as set out in this Certificate.

On behalf of the British Board of Agrément

Paul Valentine
Technical Excellence Director

Claire Curtis-Thomas
Chief Executive

Date of Second issue: 24 June 2019

Originally certificated on 21 August 2014

The BBA is a UKAS accredited certification body – Number 113.

*The schedule of the current scope of accreditation for product certification is available in pdf format via the UKAS link on the BBA website at www.bbacerts.co.uk
Readers are advised to check the validity and latest issue number of this Agrément Certificate by either referring to the BBA website or contacting the BBA direct.
Any photographs are for illustrative purposes only, do not constitute advice and should not be relied upon.*

British Board of Agrément

Bucknalls Lane
Watford
Herts WD25 9BA

©2019

tel: 01923 665300
clientservices@bbacerts.co.uk
www.bbacerts.co.uk

Regulations

In the opinion of the BBA, Toplite Standard and Foundation, if installed, used and maintained in accordance with this Certificate, can satisfy or contribute to satisfying the relevant requirements of the following Building Regulations (the presence of a UK map indicates that the subject is related to the Building Regulations in the region or regions of the UK depicted):



The Building Regulations 2010 (England and Wales) (as amended)

Requirement:	A1	Loading
Requirement:	A2	Ground movement
Comment:		Walls designed for, and constructed from, the products can satisfy these Requirements. See sections 4, 6.1 and 6.2 of this Certificate.
Requirement:	B3(1)(2)(3)(a)(4)	Internal fire spread (structure)
Comment:		The products can contribute to a construction satisfying this Requirement. See sections 9.1 to 9.3 of this Certificate.
Requirement:	B4(1)	External fire spread
Comment:		In England, the products can contribute to a construction satisfying this Requirement. See sections 9.1 to 9.3 of this Certificate.
Requirement:	C2(a)	Resistance to moisture
Comment:		The products can contribute to satisfying this Requirement. See sections 10.1 and 10.2 of this Certificate.
Requirement:	C2(b)	Resistance to moisture
Comment:		Suitably finished walls designed for, and constructed from, the products can contribute to satisfying this Requirement. See sections 4 and 11 of this Certificate.
Requirement:	C2(c)	Resistance to moisture
Comment:		Walls designed for, and constructed from, the products will contribute to limiting the risk of condensation. See sections 12.1 and 12.2 of this Certificate.
Requirement:	E1	Protection against sound from other parts of the building and adjoining buildings
Requirement:	E2(a)	Protection against sound within a dwelling-house etc
Comment:		Walls designed for, and constructed from, the products can satisfy these Requirements. See sections 8.1 to 8.3, 8.5 and 8.6 of this Certificate.
Requirement:	L1(a)(i)	Conservation of fuel and power
Comment:		Walls designed for, and constructed from, the products will contribute to limiting heat loss through walls. See section 7.1 of this Certificate.
Regulation:	7	Materials and workmanship (applicable to Wales only)
Regulation:	7(1)	Materials and workmanship (applicable to England only)
Comment:		The products are acceptable. See section 15 and the <i>Installation</i> part of this Certificate.
Regulation:	26	CO₂ emission rates for new buildings
Regulation:	26A	Fabric energy efficiency rates for new dwellings (applicable to England only)
Regulation:	26A	Primary energy consumption rates for new buildings (applicable to Wales only)
Regulation:	26B	Fabric performance values for new dwellings (applicable to Wales only)
Comment:		The products can contribute to satisfying these Regulations when compensating fabric/services measures are taken. See section 7.1 of this Certificate.



The Building (Scotland) Regulations 2004 (as amended)

Regulation:	8(1)	Durability, workmanship and fitness of materials
Comment:		Use of the products satisfies the requirements of this Regulation. See section 15 and the <i>Installation</i> part of this Certificate.
Regulation:	9	Building standards applicable to construction
Standard:	1.1(a)(b)	Structure
Comment:		Walls designed for, and constructed from, the products can satisfy this Standard, with reference to clauses 1.1.1 ⁽¹⁾⁽²⁾ to 1.1.3 ⁽¹⁾⁽²⁾ . See sections 4, 6.1 and 6.2 of this Certificate.
Standard:	2.1	Compartmentation
Standard:	2.2	Separation
Standard:	2.3	Structural protection
Standard:	2.4	Cavities
Standard:	2.6	Spread to neighbouring buildings
Comment:		The products can contribute to a construction satisfying these Standards, with reference to clauses 2.1.1 ⁽²⁾ , 2.1.4 ⁽²⁾ , 2.1.5 ⁽²⁾ , 2.1.8 ⁽²⁾ , 2.1.9 ⁽²⁾ , 2.1.10 ⁽²⁾ , 2.1.11 ⁽²⁾ , 2.1.12 ⁽²⁾ , 2.1.13 ⁽²⁾ , 2.1.15 ⁽²⁾ , 2.2.1 to 2.2.5 ⁽¹⁾⁽²⁾ , 2.2.8 ⁽¹⁾ , 2.2.10 ⁽¹⁾ , 2.3.1 ⁽¹⁾⁽²⁾ to 2.3.5 ⁽¹⁾⁽²⁾ , 2.4.2 ⁽¹⁾⁽²⁾ , 2.6.1 ⁽¹⁾⁽²⁾ , 2.6.5 ⁽¹⁾ , 2.6.6 ⁽¹⁾⁽²⁾ and 2.6.7 ⁽²⁾ . See sections 9.1 to 9.3 of this Certificate.
Standard:	3.4	Moisture from the ground
Comment:		The products can contribute to satisfying this Requirement. See sections 10.1 and 10.2 of this Certificate.
Standard:	3.10	Precipitation
Comment:		Suitably finished walls designed for, and constructed from, the products can contribute to satisfying this Standard, with reference to clauses 3.10.1 ⁽¹⁾⁽²⁾ , 3.10.2 ⁽¹⁾⁽²⁾ , 3.10.3 ⁽¹⁾⁽²⁾ and 3.10.6 ⁽¹⁾⁽²⁾ . See sections 4.4 and 11 of this Certificate.
Standard:	3.15	Condensation
Comment:		Walls designed for, and constructed from, the products can contribute to limiting the risk of condensation, with reference to clauses 3.15.1 ⁽¹⁾⁽²⁾ , 3.15.4 ⁽¹⁾⁽²⁾ and 3.15.5 ⁽¹⁾⁽²⁾ of this Standard. See sections 12.1 and 12.2 of this Certificate.
Standard:	5.1	Noise separation
Comment:		Walls designed for, and constructed from, the products can satisfy this Standard, with reference to clauses 5.1.1 ⁽¹⁾⁽²⁾ to 5.1.5 ⁽¹⁾⁽²⁾ . See sections 8.1, 8.4 and 8.5 of this Certificate.
Standard:	5.2	Noise reduction between rooms
Comment:		Walls designed for, and constructed from, the products can satisfy this Standard, with reference to clauses 5.2.1 ⁽¹⁾⁽²⁾ and 5.2.2 ⁽¹⁾⁽²⁾ . See sections 8.1, 8.4 and 8.5 of this Certificate.
Standard:	6.1(b)	Carbon dioxide emissions
Standard:	6.2	Building insulation envelope
Comment:		Walls designed for, and constructed from, the products can contribute to satisfying these Standards, with reference to clauses 6.1.1 ⁽¹⁾ , 6.1.2 ⁽¹⁾ , 6.1.4 ⁽²⁾ , 6.1.6 ⁽¹⁾ , 6.2.1 ⁽¹⁾⁽²⁾ , 6.2.3 ⁽¹⁾ , 6.2.4 ⁽²⁾ , 6.2.5 ⁽²⁾ , 6.2.6 ⁽¹⁾ , 6.2.7 ⁽¹⁾ , 6.2.8 ⁽¹⁾⁽²⁾ , 6.2.9 ⁽¹⁾⁽²⁾ , 6.2.10 ⁽²⁾ , 6.2.11 ⁽¹⁾⁽²⁾ , 6.2.12 ⁽¹⁾⁽²⁾ and 6.2.13 ⁽¹⁾⁽²⁾ . See section 7.1 of this Certificate.
Standard:	7.1(a)	Statement of sustainability

Comment:		The products can contribute to satisfying the relevant requirements of Regulation 9, Standards 1 to 6, and therefore will contribute to a construction satisfying a bronze level of sustainability as defined in this Standard.
Regulation:	12	Building standards applicable to conversions
Comment:		Comments made in relation to the products under Regulation 9, Standards 1 to 6, also apply to this Regulation, with reference to clause 0.12.1 ⁽¹⁾⁽²⁾ and Schedule 6 ⁽¹⁾⁽²⁾ .
		(1) Technical Handbook (Domestic). (2) Technical Handbook (Non-Domestic).



The Building Regulations (Northern Ireland) 2012 (as amended)

Regulation:	23(a)(i)(iii)(b)	Fitness of materials and workmanship
Comment:		The products are acceptable. See section 15 and the <i>Installation</i> part of this Certificate.
Regulation:	28(b)	Resistance to moisture and weather
Comment:		Suitably finished walls designed for, and constructed from, the products can contribute to satisfying this Regulation. See sections 4.4, 10.1, 10.2 and 11 of this Certificate.
Regulation:	29	Condensation
Comment:		Walls designed for, and constructed from, the products can contribute to limiting the risk of condensation. See section 12.2 of this Certificate.
Regulation:	30(a)	Stability
Comment:		Walls designed for, and constructed from, the products can satisfy this Regulation. See sections 4, 6.1 and 6.2 of this Certificate.
Regulation:	35(1)(2)(3)(4)	Internal fire spread - Structure
Regulation:	36(a)	External fire spread
Comment:		The products can contribute to a construction satisfying these Regulations. See sections 9.1 to 9.3 of this Certificate.
Regulation:	39(a)(i)	Conservation measures
Comment:		Walls designed for, and constructed from, the products can contribute to limiting heat loss through walls. See section 7.1 of this Certificate.
Regulation:	40(2)	Target carbon dioxide emissions rate
Comment:		Walls designed for, and constructed from, the products can contribute to satisfying this Regulation. See section 7.1 of this Certificate.
Regulation:	49	Protection against sound from other parts of the building and from adjoining buildings
Comment:		Walls designed for, and constructed from, the products can satisfy this Regulation. See sections 8.1 to 8.3 and 8.6 of this Certificate.
Regulation:	50(a)	Protection against sound within a dwelling or room for residential purposes
Comment:		Walls designed for, and constructed from, the products can satisfy this Regulation. See sections 8.1 to 8.3 and 8.6 of this Certificate.

Construction (Design and Management) Regulations 2015

Construction (Design and Management) Regulations (Northern Ireland) 2016

Information in this Certificate may assist the client, designer (including Principal Designer) and contractor (including Principal Contractor) to address their obligations under these Regulations.

See sections: **1 Description (1.2) and 3 Delivery and site handling (3.1)** of this Certificate.

Additional Information

NHBC Standards 2019

In the opinion of the BBA, Toplite Standard and Foundation blocks, if installed, used and maintained in accordance with this Certificate, can satisfy or contribute to satisfying the relevant requirements in relation to *NHBC Standards*, Chapters 5.1 *Substructure and ground bearing floors*, 6.1 *External masonry walls* and 6.3 *Internal walls*.

CE marking

The Certificate holder has taken the responsibility of CE marking the products in accordance with harmonised Standard BS EN 771-4 : 2011. An asterisk (*) appearing in this Certificate indicates that data shown are given in the manufacturer's Declaration of Performance.

Technical Specification

1 Description

1.1 Toplite Standard and Foundation are general purpose Aircrete blocks comprising cement, lime, paper ash and fine sand, with aluminium powder used as an aerating agent.

1.2 The blocks are supplied with the characteristics detailed in Table 1 and the dimensions detailed in Table 2.

Table 1 Block characteristics

Characteristic (unit)	Value
Gross dry density* ($\text{kg}\cdot\text{m}^{-3}$)	630
Dry density range ($\text{kg}\cdot\text{m}^{-3}$)	580 to 680
Mean compressive strength* ($\text{N}\cdot\text{mm}^{-2}$)	3.6
Minimum individual block compressive strength ($\text{N}\cdot\text{mm}^{-2}$)	2.88

Table 2 Block dimensions

Block	Face size (mm)	Thickness (mm)
Toplite Standard	440 x 215	75 to 215
Toplite Foundation	440 x 215	275 to 300

1.3 Coursing units are also available.

2 Manufacture

2.1 The blocks are manufactured by mixing the raw materials into a slurry which is discharged into moulds. The slurry rises and sets to form a cake which is then cut into blocks of the required dimensions using tensioned wires. Curing takes place in autoclaves under steam and pressure to increase the physical and chemical stability of the blocks, before they are removed and packaged.

2.2 As part of the assessment and ongoing surveillance of product quality, the BBA has:

- agreed with the manufacturer the quality control procedures and product testing to be undertaken
- assessed and agreed the quality control operated over batches of incoming materials
- monitored the production process and verified that it is in accordance with the documented process
- evaluated the process for management of nonconformities
- checked that equipment has been properly tested and calibrated
- undertaken to carry out the above measures on a regular basis through a surveillance process, to verify that the specifications and quality control operated by the manufacturer are being maintained.

2.3 The management system of Tarmac Building Products Limited has been assessed and registered as meeting the requirements of BS EN ISO 9001 : 2015 by BSI (Certificate FM 00948).

3 Delivery and site handling

3.1 The blocks are supplied banded and shrink-wrapped in standard packs, or banded and shrink-wrapped to pallets (to order) which are suitable for off-loading with mechanical grabs or fork-lift trucks.

3.2 The blocks must be stored clear of the ground on a firm, level surface and protected from rain and water from the ground. The shrink-wrapping should be kept in place until the blocks are required for use.

Assessment and Technical Investigations

The following is a summary of the assessment and technical investigations carried out on Toplite Standard and Foundation.

Design Considerations

4 Use



4.1 Toplite Standard and Foundation are suitable for use in the construction of loadbearing and non-loadbearing solid internal and external walls above and below the damp-proof course, and the inner and outer leaves of cavity walls.

4.2 The blocks comply with the requirements of BS EN 771-4 : 2011.

4.3 The blocks should be specified in accordance with BS EN 771-4 : 2011 and BS 6073-2 : 2008.

4.4 Walls must be designed and constructed in accordance with BS 5250 : 2011, BS 8215 : 1991, BS EN 1996-1-1 : 2005, BS EN 1996-1-2 : 2005, BS EN 1996-2 : 2006 and BS EN 1996-3 : 2006 and their UK National Annexes, and PD 6697 : 2010.

5 Practicability of installation

The products are designed to be installed by a competent general builder, or a contractor, experienced with these types of products.

6 Strength and stability

General



6.1 Coursing should be set out so bearings are at least 100 mm in length or the length required by the design calculation, whichever is the greater. Where possible, the masonry should be set out to provide a full block under a bearing. Pressed steel lintels should have a bearing of at least 150 mm.

Concentrated loads

6.2 Increased local stresses may be permitted in the masonry provided that the member applying the load is sensibly rigid and of appropriate bearing area or a suitable spreader is introduced. Design should be in accordance with BS EN 1996-1-1 : 2005, Clause 6.1.3 and its UK National Annex.

6.3 Joist hangers may be used provided that:

- when designing in accordance with BS EN 1996-1-1 : 2005 and its UK National Annex and/or PD 6697 : 2010, the full effect of the maximum eccentric load at the joist hanger detail is taken into account. It should be assumed

that joist hangers are not effectively rigid when calculating the local bearing stress under single hangers; the effective load applied via the hanger should be determined by an acceptable elastic theory

- they are compatible with Aircrete blocks with mean compressive strengths* of $3.6 \text{ N}\cdot\text{mm}^{-2}$ or above. The dimensions used in the design and the manufacture from appropriate materials are set out in BS EN 845-1 : 2013 and BS EN 1996-2 : 2006, Annex C, Table C1 and its UK National Annex
- supervision and quality of work⁽¹⁾ are adequate to ensure that:
 - installation is in accordance with the hanger manufacturer's instructions
 - the masonry course to carry the hangers is level and at the correct height, any adjustments being made before the course is laid
 - the hanger bears directly on a complete block with the back plate flat against the block
 - the gap between the joist and the back plate does not exceed 6 mm
 - construction complies with the conditions used in the design and restraint-type hangers are used when specified
 - the blockwork above the hanger is completed and matured before any load is applied to the hanger.

(1) Further guidance may be obtained from the BRE *Good Building Guide 21 (1996): Joist hangers*.

6.4 The characteristic initial shear strength of designed masonry mortars in combination with the blocks must be as follows, in accordance with BS EN 998-2 : 2016:

- $0.15 \text{ N}\cdot\text{mm}^2$ for general purpose and lightweight mortar
- $0.3 \text{ N}\cdot\text{mm}^2$ for thin layer mortar.

6.5 Flexural strength values f_{xk1} and f_{xk2} to be used for general purpose mortars are given in BS EN 1996-1-1 : 2005 and its UK National Annex, Table NA.6.

7 Thermal performance



7.1 Thermal transmittance (U value) calculations of walls should be carried out in accordance with BS EN ISO 6946 : 2017 and BRE Report BR 443 : 2006. The conductivity of the blocks should be taken as $0.16 \text{ W}\cdot\text{m}^{-1}\cdot\text{K}^{-1}$ for 'protected blockwork', $0.17 \text{ W}\cdot\text{m}^{-1}\cdot\text{K}^{-1}$ for external blockwork exposed (eg not protected by a cladding system) or below the damp-proof course but above ground level, and $0.25 \text{ W}\cdot\text{m}^{-1}\cdot\text{K}^{-1}$ for blockwork below ground level.

7.2 Walls incorporating the blocks will need to include thermal insulation as necessary to achieve or improve on (as appropriate) the following 'mean' design U values specified in:

England — 0.18 to $0.35 \text{ W}\cdot\text{m}^{-2}\cdot\text{K}^{-1}$

Wales — 0.21 to $0.35 \text{ W}\cdot\text{m}^{-2}\cdot\text{K}^{-1}$

Scotland — 0.19 to $0.30 \text{ W}\cdot\text{m}^{-2}\cdot\text{K}^{-1}$

Northern Ireland — 0.26 to $0.35 \text{ W}\cdot\text{m}^{-2}\cdot\text{K}^{-1}$.

7.3 The products can contribute to maintaining continuity of thermal insulation at junctions between elements and around openings. Guidance on limiting heat loss by air infiltration can be found in:

England and Wales — Accredited Construction Details (version 1.0)

Scotland — Accredited Construction Details (Scotland)

Northern Ireland — Accredited Construction Details (version 1.0).

7.4 Further information can be found in the NHBC Foundation's *A practical guide to building airtight dwellings (NF16)* (June 2009).

8 Sound insulation

Separating walls



8.1 Separating walls in England and Wales, Northern Ireland and Scotland, excluding those covered by the Robust Details Ltd scheme, are subject to pre-completion testing. However, the following constructions, together with their associated flanking elements, should achieve acceptable resistance to airborne sound transmission:

New buildings

England and Wales

- constructed in accordance with the Robust Details Ltd scheme and Approved Document E, paragraph 0.2, between dwellings or flats
- wall types 2.4 or 3.3 described in Approved Document E
- a wall described in section 7.2 of this Certificate
- a wall satisfying the minimum sound insulation values in Approved Document E, Table 0.1a or 0.1b as appropriate

Scotland

- a wall satisfying the minimum sound insulation values in the Technical Handbooks, clause 5.1.2

Northern Ireland

- constructed in accordance with the Robust Details Ltd scheme and Technical Booklet G, paragraph 0.14, between dwellings or flats
- a wall described in section 7.2 of this Certificate
- a wall satisfying the minimum sound transmission values in Technical Booklet G, Tables 1a and 1b

Conversions

England and Wales

- a wall satisfying the requirements for new buildings
- a wall similar to a wall satisfying the requirements for new buildings, as described in Approved Document E, sections 4 or 6
- a wall treatment 1 described in Approved Document E, paragraphs 4.22 to 4.25

Scotland

- a wall satisfying the requirements for new buildings

Northern Ireland

- a wall satisfying the requirements for new buildings
- a wall similar to a wall satisfying the requirements for new buildings, as described in Technical Booklet G, sections 4 or 6
- a wall treatment 1 described in Technical Booklet G, paragraph 4.22 to 4.25.



8.2 Separating walls constructed with a cavity comprising two 100 mm thick leaves and complying with the following provisions will adequately limit airborne sound transmission:

- the wall cavity must be at least 75 mm wide and must be continued into the roof space
- all vertical and horizontal joints must be filled with mortar not exceeding a strength of 1:1:6
- penetration by structural members and services should be avoided; where such penetration is unavoidable, full sealing must be applied at the construction stage
- where joists are at right angles to the separating wall, joist hangers must be used
- wall ties should be of type A to Approved Document E or an alternative proven not to increase the transmission of airborne sound in comparison; this may be determined by test evidence or by reference to a BBA Certificate
- electrical and TV sockets must not be placed on the wall where avoidable, and never within a block length of each other on opposite sides of the wall
- gas flues must not be built into the separating wall; where such construction is unavoidable, full sealing must be applied at the construction stage
- the walls must be finished with plasterboard on dabs or plaster to both room faces (this finish need not be carried into the roof space)
- the use of lightweight ceiling boards (for example, foam-filled), must be avoided.

Walls flanking a separating wall or floor



8.3 The blocks can form the inner leaf of an external masonry cavity wall described in the following documents where any leaf surface mass excluding finishes is acceptable (for example, where there is no separating floor):

England and Wales — Approved Document E, Sections 2 and 3

Northern Ireland — Technical Booklet G, Sections 2 and 3.



8.4 The blocks can form the inner leaf of an external masonry cavity wall flanking a Type 2 separating wall where there is no separating floor and the minimum block density is $450 \text{ kg}\cdot\text{m}^{-3}$ as described in the Building Standards Division Publication *Example construction and generic internal constructions*, Section *Generic Internal Constructions*, referred to in the Technical Handbooks, clause 5.1.3.

Internal walls — new buildings and conversions



8.5 Internal walls between a bedroom, or a room containing a toilet, and other rooms (in England and Wales), or between an apartment in a dwelling and a room in a residential building which is capable of being used for sleeping (in Scotland), are acceptable as follows:

England and Wales — a wall type D described in Approved Document E, paragraph 5.20, and a wall satisfying the minimum sound insulation values in Approved Document E, Table 0.2

Scotland — a wall Type 4 and 4A described in the *Generic Internal Constructions* referred to in the Technical Handbooks clause 5.2.2, and a wall satisfying the minimum sound insulation values in the Technical Handbooks, clause 5.2.1.



8.6 The blocks can form an internal partition abutting a Type 1, 2 or 4 separating wall or a Type 1 or 2 separating floor if the minimum surface mass, excluding finishes of the partition, is at least $120 \text{ kg}\cdot\text{m}^{-2}$. Guidance on circumstances where any surface mass can be acceptable (for example, where there is no separating floor) can be found in the following documents:

England and Wales — Approved Document E, Sections 2 and 3

Northern Ireland — Technical Booklet G, Sections 2 and 3.

9 Properties in relation to fire



9.1 The fire resistance of walls constructed with Aircrete masonry can be determined by reference to:

- BS EN 1996-1-2 : 2005, Annex B, Table NB 4.6 and its UK National Annex, Tables NA 3.10 to NA 3.12
- BRE Report BR 128 : 1988.

9.2 The blocks have a reaction to fire classification* of Class A1 to BS EN 13501-1 : 2007 and are classified as non-combustible as defined in the national Building Regulations.

9.3 With regard to the placing of cavity barriers, the surface of the products may be taken as Class 0.

9.4 The fire performance and suitability of wall ties and anchors for a specific construction should be confirmed with the manufacturer of the products.

10 Use below the damp-proof course



10.1 The blocks are resistant to freeze/thaw conditions likely to occur below the damp-proof course and are therefore suitable for use in situations up to and including MX3.2 as defined in BS EN 1996-2 : 2006, Annex A, Table A1 and its UK National Annex.

10.2 The blocks are suitable for use in Classes DS1, DS2 and DS3 of soil or groundwater as defined in BRE Special Digest 1 : 2005, Part C *Assessing the aggressive chemical environment*.

10.3 In unusual soil and/or groundwater conditions, eg soils contaminated by industrial waste or highly acidic soils, expert advice should be obtained.

11 Resistance to moisture



11.1 Walls built from the blocks should be designed and constructed in accordance with:

England and Wales — Approved Document C

Scotland — Mandatory Standard 3.10, clauses 3.10.1⁽¹⁾⁽²⁾ to 3.10.4⁽¹⁾⁽²⁾ and 3.10.6⁽¹⁾⁽²⁾

(1) Technical Handbook (Domestic).

(2) Technical Handbook (Non-Domestic).

Northern Ireland — Technical Booklet C.

11.2 For single leaf constructions, the minimum block thicknesses to be used in solid rendered external walls are given in Table 3.

Table 3 Minimum block thicknesses⁽¹⁾

Exposure ⁽²⁾	Minimum block thickness (mm)
Severe	215
Moderate	190
Sheltered	90

(1) Increased thicknesses may be necessary to satisfy other requirements such as structural stability (see sections 4.4, 6 and 7).

(2) The exposure is defined in PD 6697 : 2010.

12 Condensation risk



12.1 Walls will adequately limit the risk of surface condensation when the thermal transmittance (U value) does not exceed $0.7 \text{ W}\cdot\text{m}^{-2}\cdot\text{K}^{-1}$ ($1.2 \text{ W}\cdot\text{m}^{-2}\cdot\text{K}^{-1}$ in Scotland) at any point and the junctions with floors, roof and openings comply with section 7.3.



12.2 Walls will adequately limit the risk of interstitial condensation when they are constructed in accordance with BS 5250 : 2011 (Section 4 and Annexes D and G). For the purpose of calculations, the block's water vapour resistance factor (μ) may be taken as 10 (with a resistivity of $50 \text{ MN}\cdot\text{s}^{-1}\cdot\text{g}^{-1}\cdot\text{m}^{-1}$) as given in BS EN ISO 10456 : 2007, Table 4.

12.3 Additional guidance can be found in BRE Report BR 262 : 2002.

13 Movement

13.1 The maximum declared moisture movement of the blocks may be taken as a nominal value* of $0.7 \text{ mm}\cdot\text{m}^{-1}$.

13.2 Movement may be accommodated using movement joints or bed joint reinforcement, or a combination of the two. When bed joint reinforcement is intended to contribute towards accommodation of movement, it should be designed and installed strictly in accordance with the Certificate holder's instructions.

13.3 Movement joints must be provided in accordance with BS EN 1996-2 : 2006 , clause 2.3.4, and its UK National Annex Clause NA.2.1, PD 6697 : 2010, Table NA.1 and the Certificate holder's instructions.

13.4 In external walls containing openings, movement joints may need to be provided at more frequent intervals, or the masonry above and below the opening may need to be reinforced to restrain movement. Particular attention should be paid to long, low, horizontal panels of masonry, eg those under windows.

14 Maintenance

As the blocks are generally concealed and have suitable durability (see section 15), maintenance is not required.

15 Durability



Autoclaved aerated concrete (Aircrete) is a durable material. Walls constructed from the products will have durability equivalent to those of traditional masonry and will fulfil their intended function for the life of the building in which they have been installed.

Installation

16 General

16.1 Installation of Toplite Standard and Foundation must be carried out strictly in accordance with BS 8000-3 : 2001, the Certificate holder's instructions and this Certificate.

16.2 Mortar must not be stronger than the blocks, using the definitions in:

- BS EN 1996-1-1 : 2005 and its UK National Annex, Table NA.2
- PD 6697 : 2010, Table 15.

17 Chasing

The maximum depth of horizontal and vertical chases allowed without calculation is given in BS EN 1996-1-1 : 2005, clauses 8.6.1 to 8.6.3, and its UK National Annex, Tables NA.11 and NA.12.

18 Rendering and plastering

Rendering and plastering must be carried out in accordance with BS EN 13914-1 : 2016 and BS EN 13914-2 : 2016. The Certificate holder should be consulted regarding suitable finishes and low water-vapour-permeability renders. The moisture condition of the blocks should be considered before the finishes are applied.

19 Fixings

19.1 Cut nails or proprietary nails may be used for lightweight fixtures. Screws and plugs, nailable expansion fixings or helical fixings should be used for heavier fixtures. All fixings must penetrate a minimum of 50 mm into the blocks.

19.2 Fixings must be selected and installed in accordance with the fixing manufacturer's instructions, paying particular attention to drilling depth, drill diameter, minimum spacings and minimum edge distance.

19.3 Mean pull-out loads for certain proprietary fixings used with the blocks can be obtained from the Certificate holder. In each case, a safety factor of 4 is recommended to establish a safe working load.

Technical Investigations

20 Tests

20.1 Tests were carried out and the results assessed to determine:

- dimensional accuracy
- dry density
- compressive strength
- assessment of freeze/thaw resistance comparative tests
- effect of water on compressive strength
- natural exposure

- thermal conductivity.

20.2 An assessment of the durability of the products was made, based on data resulting in the issue of previous BBA Certificates.

21 Investigations

21.1 An assessment was made of data to determine:

- acoustic performance
- behaviour in fire.

21.2 The manufacturing process was evaluated, including the methods adopted for quality control, and details were obtained of the quality and composition of the materials used.

Bibliography

BRE Report BR 128 : 1988 *Guidelines for the construction of fire-resisting structural elements*

BRE Report BR 262 : 2002 *Thermal insulation : avoiding risks*

BRE Report BR 443 : 2006 *Conventions for U value calculations*

BRE Special Digest 1 : 2005 *Concrete in aggressive ground*

BS 5250 : 2011 + A1 : 2016 *Code of practice for control of condensation in buildings*

BS 6073-2 : 2008 *Precast concrete masonry units — Guide for specifying precast concrete masonry units*

BS 8000-3 : 2001 *Workmanship on building sites — Code of practice for masonry*

BS 8215 : 1991 *Code of practice for design and installation of damp-proof courses in masonry construction*

BS EN 771-4 : 2011 + A1 : 2015 *Specification for masonry units — Autoclaved aerated concrete masonry units*

BS EN 845-1 : 2013 *Specification for ancillary components for masonry — Ties, tension straps, hangers and brackets*

BS EN 998-2 : 2016 *Specification for mortar for masonry — Masonry mortar*

BS EN 1996-1-1 : 2005 + A1 : 2012 *Eurocode 6 — Design of masonry structures — General rules for reinforced and unreinforced masonry structures*

NA to BS EN 1996-1-1 : 2005 + A1 : 2012 *Eurocode 6 — Design of masonry structures — General rules for reinforced and unreinforced masonry structures*

BS EN 1996-1-2 : 2005 *Eurocode 6 — Design of masonry structures — General rules — Structural fire design*

NA to BS EN 1996-1-2 : 2005 *Eurocode 6 — Design of masonry structures — General rules — Structural fire design*

BS EN 1996-2 : 2006 *Eurocode 6 — Design of masonry structures — Design considerations, selection of materials and execution of masonry*

NA to BS EN 1996-2 : 2006 *Eurocode 6 — Design of masonry structures — Design considerations, selection of materials and execution of masonry*

BS EN 1996-3 : 2006 *Eurocode 6 — Design of masonry structures — Simplified calculation methods for unreinforced masonry structures*

NA to BS EN 1996-3 : 2006 *UK National Annex to Eurocode 6 — Design of masonry structures — Simplified calculation methods for unreinforced masonry structures*

BS EN 13501-1 : 2007 *Fire classification of construction products and building elements — Classification using test data from reaction to fire tests*

BS EN 13914-1 : 2016 *Design, preparation and application of external rendering and internal plastering — External rendering*

BS EN 13914-2 : 2016 *Design, preparation and application of external rendering and internal plastering — Design considerations and essential principles for internal plastering*

BS EN ISO 6946 : 2017 *Building components and building elements — Thermal resistance and thermal transmittance — Calculation method*

BS EN ISO 9001 : 2015 *Quality management systems — Requirements*

BS EN ISO 10456 : 2007 *Building materials and products — Hygrothermal properties — Tabulated design values and procedures for determining declared and design thermal values*

PD 6697 : 2010 *Recommendations for the design of masonry structures to BS EN 1996-1-1 and BS EN 1996-2*

22 Conditions

22.1 This Certificate:

- relates only to the product/system that is named and described on the front page
- is issued only to the company, firm, organisation or person named on the front page – no other company, firm, organisation or person may hold or claim that this Certificate has been issued to them
- is valid only within the UK
- has to be read, considered and used as a whole document – it may be misleading and will be incomplete to be selective
- is copyright of the BBA
- is subject to English Law.

22.2 Publications, documents, specifications, legislation, regulations, standards and the like referenced in this Certificate are those that were current and/or deemed relevant by the BBA at the date of issue or reissue of this Certificate.

22.3 This Certificate will remain valid for an unlimited period provided that the product/system and its manufacture and/or fabrication, including all related and relevant parts and processes thereof:

- are maintained at or above the levels which have been assessed and found to be satisfactory by the BBA
- continue to be checked as and when deemed appropriate by the BBA under arrangements that it will determine
- are reviewed by the BBA as and when it considers appropriate.

22.4 The BBA has used due skill, care and diligence in preparing this Certificate, but no warranty is provided.

22.5 In issuing this Certificate the BBA is not responsible and is excluded from any liability to any company, firm, organisation or person, for any matters arising directly or indirectly from:

- the presence or absence of any patent, intellectual property or similar rights subsisting in the product/system or any other product/system
- the right of the Certificate holder to manufacture, supply, install, maintain or market the product/system
- actual installations of the product/system, including their nature, design, methods, performance, workmanship and maintenance
- any works and constructions in which the product/system is installed, including their nature, design, methods, performance, workmanship and maintenance
- any loss or damage, including personal injury, howsoever caused by the product/system, including its manufacture, supply, installation, use, maintenance and removal
- any claims by the manufacturer relating to CE marking.

22.6 Any information relating to the manufacture, supply, installation, use, maintenance and removal of this product/system which is contained or referred to in this Certificate is the minimum required to be met when the product/system is manufactured, supplied, installed, used, maintained and removed. It does not purport in any way to restate the requirements of the Health and Safety at Work etc. Act 1974, or of any other statutory, common law or other duty which may exist at the date of issue or reissue of this Certificate; nor is conformity with such information to be taken as satisfying the requirements of the 1974 Act or of any statutory, common law or other duty of care.